

MATERIAL:  
 DUCTILE IRON / STEEL / ALUMINUM  
 VITON

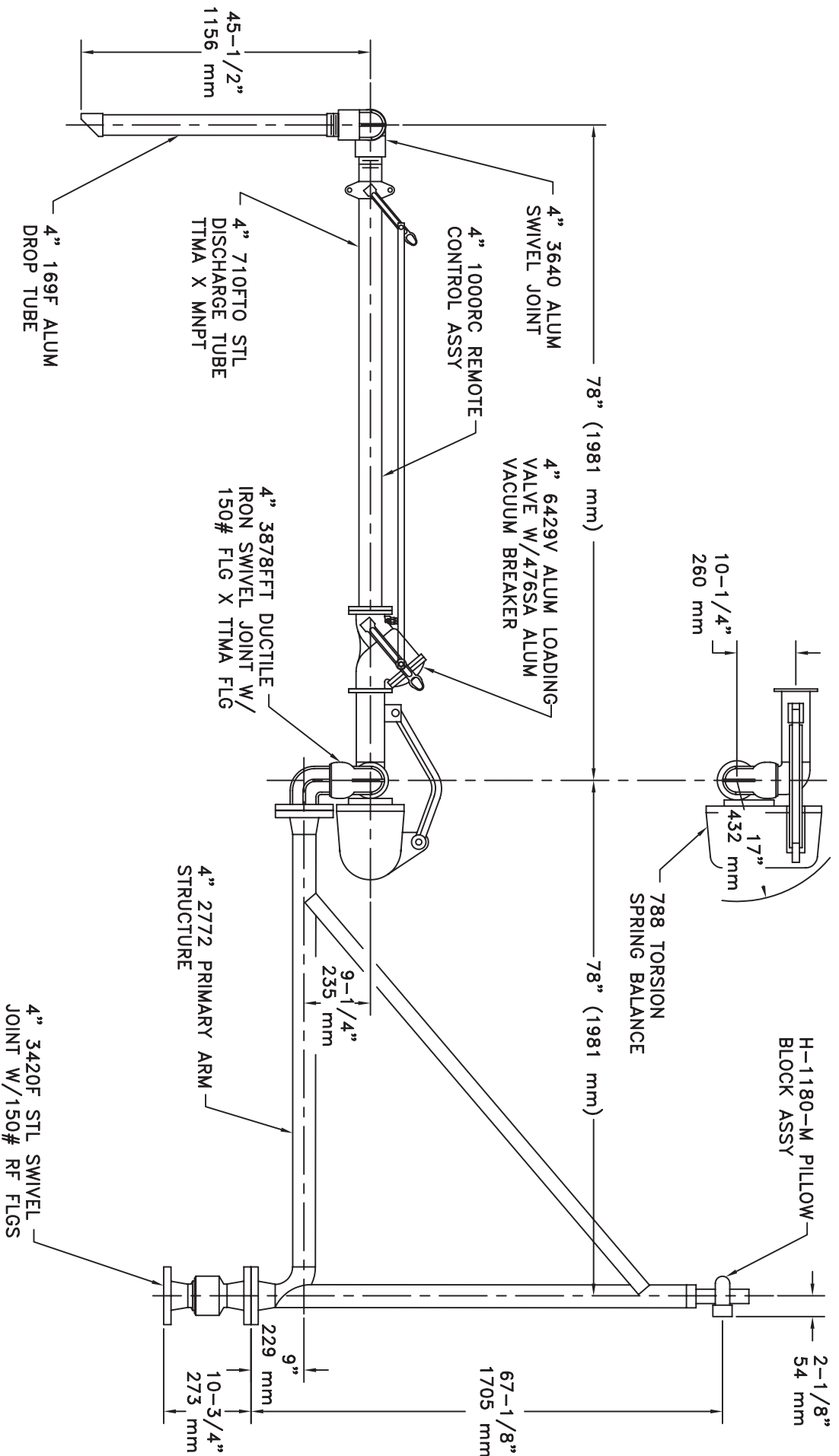

4" OPW B32RF LIQUID LOADER



ARM IS DESIGNED FOR PRODUCT RETENTION TO POINT OF VALVE

Distributed by:



3, Poruchik Nedelcho Bonchev Str., fl. 5, 1528 Sofia, Bulgaria  
 tel: +359 2 973 27 67, e-mail: office@daisglobal.eu