

→ Series 684

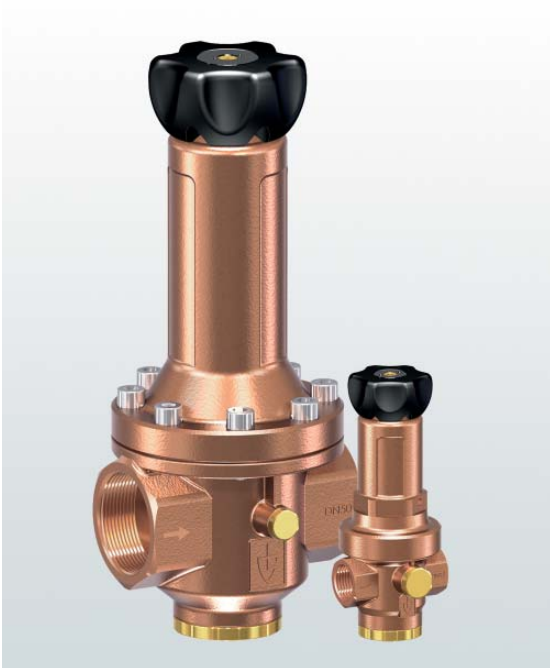

■ SUITABLE FOR

Liquids	neutral and non-neutral	
Air, gases and vapours	neutral and non-neutral	

■ EXAMPLES OF USE

For the protection of:
- commercial and industrial plants
against too high supply pressure.
Use of pressure reducing valves, when in a piping system inspite of
varying pressures on the inlet side a specific pressure on the outlet
side must be kept.

- compressed air supply plants
- pneumatic control units
- pressure booster plants air-side
- shipbuilding industry and offshore plants

■ APPROVALS

European Pressure Equipment Directive	
GOST-TR	
Requirements PED 97/23/EC	
Classification society	
Germanischer Lloyd Lloyd's Register EMEA	GL LR EMEA



■ MATERIAL



■ SPECIFICATION



1/4" – 2"



– 10°C to + 120°C
depending on
version



Inlet pressure:
up to 60 bar
Outlet pressure:
0,5 to 50 bar
depending on version

■ MATERIALS

Component	Material	DIN EN	ASME
Inlet body	Gunmetal	CC499K	CC499K
Outlet body	Gunmetal	CC499K	CC499K
Internal parts	Brass	CW617N	CW617N
Spring	Spring steel with anti-rust protection	1.1200	ASTM A228

■ VALVE VERSION

m	with diaphragm	High-quality heat-resistant elastomere, fabric reinforced diaphragm. Adjustment by means of non-rising spindle. Balanced single seat valve, pressure gauge connection G1/4" on both sides of body. Please take note of the outlet pressure range.
k	with piston	Brass piston with seal and support ring. Please take note of the outlet pressure ranges.

■ MEDIUM

G	gaseous	Compressed air and gases
GF	gaseous and liquid	for water and non-sticking liquids, compressed air and gases

■ SECONDARY VENTING

S	with secondary venting	for neutral and non-toxic gases
O	without secondary venting	for liquids, neutral and non-neutral gases

■ OUTLET PRESSURE RANGES

SM	Standard version with diaphragm	Inlet pressure: up to 60 bar	Outlet pressure: 0,5 to 15 bar
SK HK	Standard version with piston High-pressure version with piston	Inlet pressure: up to 60 bar Inlet pressure: up to 60 bar	Outlet pressure: 5 to 30 bar Outlet pressure: 10 to 50 bar

Fixed setting at a required outlet pressure against surcharge

■ AVAILABLE NOMINAL DIAMETERS AND CONNECTION SIZES

Nominal diameter DN	8	10	15	20	25	40	50
Inlet female connection	1/4" (8)	3/8" (10)	1/2" (15)	3/4" (20)	1" (25)	1 1/2" (40)	2" (50)
Outlet female connection	1/4" (8)	3/8" (10)	1/2" (15)	3/4" (20)	1" (25)	1 1/2" (40)	2" (50)

■ TYPE OF CONNECTION INLET / OUTLET THREADED CONNECTIONS

f / f	Standard	Female thread BSP-P / Female thread BSP-P	DIN EN ISO 228-1 / DIN EN ISO 228-1
--------------	----------	---	-------------------------------------

■ SEALS

FKM	Fluorocarbon	Elastomere moulded diaphragm and seals	-10°C to +120°C
------------	--------------	--	-----------------

■ OPTIONS AGAINST SURCHARGE

Pressure gauge 40, 44 and 45	Chapter Accessories
Addition:	
GA	ducted exhaust air in case of medium G (specific ducting of secondary venting)
Accessories:	
Modification kit S in O for version with piston	Order code: 684k Modification kit SO-DN.. -Pressure Range
Modification kit S in O for version with diaphragm	Order code: 684m Modification kit SO-DN..
Modification kit O in S for version with piston	Order code: 684k Modification kit OS-DN.. -Pressure Range
Modification kit O in S for version with diaphragm	Order code: 684m Modification kit OS-DN..
Wall mount DN40 and larger	Order code: 684 Wall mount -DN

■ NOMINAL DIAMETERS, CONNECTIONS, INSTALLATION DIMENSIONS

Series 684: Connection, installation dimensions, ranges of adjustment								
Nominal diameter	DN	8	10	15	20	25	40	50
Connection DIN EN ISO 228	G	1/4" (8)	3/8" (10)	1/2" (15)	3/4" (20)	1" (25)	1 1/2" (40)	2" (50)
Inlet pressure up to	bar	60	60	60	60	60	60	60
Outlet pressure:	SM bar	0,5-15	0,5-15	0,5-15	0,5-15	0,5-15	0,5-15	0,5-15
	SK bar	5-30	5-30	5-30	5-30	5-30	5-30	5-30
	HK bar	10-50	10-50	10-50	10-50	10-50	10-50	10-50
Installation dimensions in mm	L	68	68	60	78	102	136	136
	H	120	120	120	180	215	260	270
	h	33	33	33	40	56	63	70
	SW	26	26	26	32	44	58	70
Coefficient of flow K_{vs}	m ³ /h	1,6	1,6	1,6	3,4	5,5	12,7	12,7
Weight	kg	1,2	1,2	1,2	2,8	5,3	9,4	10,2

The K_{vs} -value was determined according to DIN 60534-1. Instructions for size and capacity definition are to be found under section 2

■ MAIN DIMENSIONS, INSTALLATION DIMENSIONS

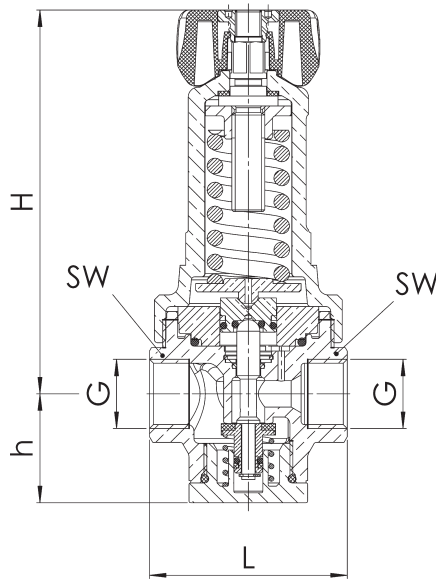

■ INDIVIDUAL SELECTION / VALVE CONFIGURATION

Series	Valve version	Medium	Secondary venting	Outlet pressure	Nominal diameter DN	Connection type		Connection size		Seal	Option	Optional feature	Quantity
						Inlet	Outlet	Inlet	Outlet				
684	m	G	S	SM	20	f	f	20	20	FKM	Pressure Gauge 40	GA	5
684	k	GF	O	SK	40	f	f	40	40	FKM			1
684						f	f			FKM			
684						f	f			FKM			

In this table you can configure a valve according to your individual requirements (similar to the *example* shown, which should be deleted before you enter your own data). Please complete the table by hand using the abbreviations in this datasheet and then fax it to: +49(0)7141.4889488
Please do not forget to add your personal data so that our sales team can contact you.

Name

First Name

Company

Telephone

E-Mail